

Estate

EXTERNAL HALYARD GROUND SET FLAGPOLE

INSTALLATION INSTRUCTIONS

Read these instructions completely before any installation is started. Pay close attention to all safety concerns. In the unlikely event that you encounter any difficulty, contact the dealer or representative from which the flagpole was purchased and if necessary they will contact us.

Warning, do not install your flagpole near overhead power lines and always be aware of anything under the soil. Contact the utility departments to confirm that it is safe to dig in the area where the flagpole is to be installed. It is advisable to have someone help in the installation. Any pole with a 5" diameter base or larger or over 25' in length may require some type of lifting device. Following a review of these instructions, the purchaser of the flagpole should determine if they are qualified to perform the installation or should obtain the services of a professional sign/flagpole installation company. Due to various methods of installation used by installers, Concord Industries, Inc. cannot be liable for structural damage or injury occurring during the flagpole assembly and installation.

1. Unwrapping and Inspection of the Shaft and Components The packaging in which the flagpole is shipped is to protect the finish during transportation. **Any tear in the package should be suspect for possible damage.** A pair of cotton gloves worn during the assembly and installation process helps to keep finger prints from the flagpole. Remove the flagpole from this shipping tube and paper wrapping when it arrives. The flagpole should be stored either in a dry area or on blocks off the ground until installation. If the flagpole gets wet with the packaging still on it, the pole may develop stains as it dries. This is the proper time to inspect the shaft for any damage that might have occurred during shipping. Verify that all parts have been received and are in good and acceptable condition.

If there is any damage to the shaft or components, do not continue with the installation without first contacting the dealer. To continue with the installation signifies the acceptance of the product in the condition received. Concord will not be responsible for later installation expenses for missing or damaged parts.

2. Foundation Preparation Prepare the foundation hole as detailed in these instructions. **Note that these dimensions are considered minimum dimensions for an in-ground or embedded flagpole in firm dry soil.** Variations in these dimensions may be needed in different soil conditions. (If your flagpole was purchased with a shoe base mount similar to a street light, there will be an additional set of installation instructions for the base. If this additional set is not included, contact the dealer before proceeding.). The diagram shows a combination of gravel and sand totaling 12". The level of gravel, used for drainage purposes, should be approximately 10" of that total amount with a layer of tamped sand above that. The sand prevents the damp concrete from blending in with the gravel when it is poured into the hole.

The PVC ground sleeve was shipped with the flagpole. On a 3" diameter pole, it will be on the inside of the shipping tube and on 4" and 5" diameter poles it will be taped on the outside of the shipping tube. Set



www.EagleMountainFlag.com
(512) 847-0010
Toll-Free (800) 385-5605
333 FM 2325 / PO Box 500
Wimberley, TX 78676

the PVC Ground Sleeve in the center of the hole with the top of the sleeve 2” above grade. Make sure the bottom of the tube is well worked into the sand. Plumb the Ground Sleeve tube vertically and brace it so it cannot move during the pouring of the concrete. You may use a simple level inserted into the sleeve to insure it is vertical. **On the 3” diameter flagpole, the pole is a snug fit in the sleeve so extra care in vertical plumbing is extremely important.** On 4” and 5” diameter flagpoles the Ground Sleeve allows for some adjustments.

Pour concrete, **continuing to verify vertical plumb** and trowel to desired finish. Keep the inside of the sleeve dry and free of debris by covering the opening. Allow the concrete to cure for at least 24 hours.

If your flagpole is a single piece shaft, refer to section 3A. If the flagpole is a multiple piece shaft, proceed to section 3B.

3A. Single Piece Flagpole Place the flagpole shaft on sawhorses in order to attach the components. For a single piece shaft, no additional steps are required before the assembly of the components. Skip Section 3B and proceed to Section 4.

3B. Multi- Section Flagpole Assembly Instructions Multiple section flagpoles are fabricated with a self aligning jam sleeve that is field assembled with close tolerances. Inspect the shaft sections for damage before any assembly. It is imperative that these sections be handled with extreme care to avoid creating an out of round condition which would prevent the sections from forming a snug fit when assembled. This is not only an appearance issue but can affect the structural integrity of the flagpole. **Do not expect to be able to disassemble the shaft sections after they have been put together. Taking them apart without damage is extremely difficult or impossible.** No hardware should be installed until the shaft sections are totally assembled. The following information is intended to be a helpful guide to the installer. Previous experience in installing multiple piece flagpoles is beneficial.

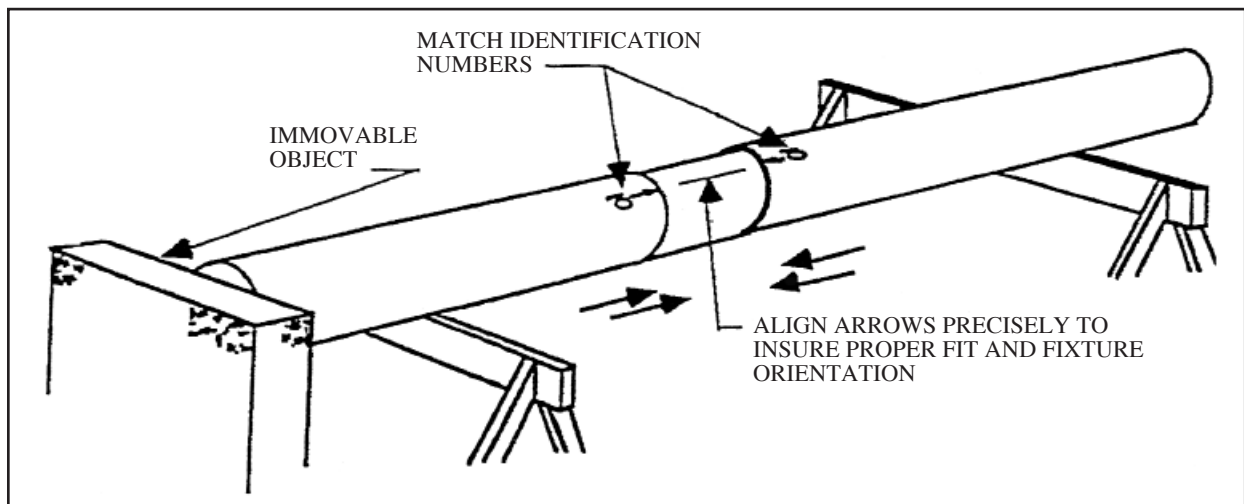

Set the bottom section on blocks or saw horses in a horizontal position with the base of the shaft against an immovable object and rotate it until the match marks can be seen. They are stamped near the ends of each section. Protect all ends with wooden blocks and padding. Check the alignment or match marks. **All numbers must be the same. If they do not, do not proceed.** They will not properly fit together. If you have purchased more than one pole, verify that all sections are grouped with the correct match number. They are not interchangeable.

Carefully clean all mating surfaces of both the outside of the jam sleeve and the inside of the bottom part of the section into which the jam sleeve will be fitted. Carefully look for and remove any debris that might be in the section after the manufacturing or shipping process. Any foreign material may stop the sections from properly fitting. Check for and remove any burrs.

Cover the jam sleeve and the appropriate amount of the inner area of the section that it will be going in to with a light layer of liquid soap. Do not use grease, oil or other petroleum products as these lubricants can seep out over time and stain the flagpole. Keep the finished surfaces of the shaft free of hand prints and excess lubricants.

Gently slide the section of the flagpole with the match mark in line with the lower section onto the jam sleeve as far as possible without forcing the two pieces together. The two pieces should be within 2" of closure. If not, gently remove the section and recheck for any obstructions. Place blocks so that the two sections have a straight centerline. If the flagpole is a 3 piece unit, debur, clean, and lubricate the next section in the same manner.

With the pieces in line, place a 4x4 block of wood against the top of the flagpole to absorb the direct shock and firmly strike the wood to drive the sections together. Excessive force, that which will damage the ends, is not necessary. If the pieces are not coming together, contact your dealer.

4. Assemble the hardware. When working with threaded components in aluminum, a light coat of an anti-seize compound is recommended. This is available at most hardware stores.

Install the cleat(s) to the 1/4"-20NC tapped holes in the flagpole. The bolt holes will be located approximately 5' above the point that the flagpole will be above the ground level. Slide the provided stainless steel screws through the cleat and start them into the pre drilled holes and snug up with a hex wrench. Be careful not to cross thread any threaded component. Do not over tighten.

String the halyard (rope) over the pulley of the cast aluminum truck (Pulley Assembly Casting). Slide the truck over the top of the pole. The standard Concord Estate Flagpole system uses a stationary truck and it can point any direction that you set it. The most common is directly over the cleat. After determining the direction of the truck, secure it to the top of the pole by tightening the set screws with an allen head wrench.

If a Revolving Truck Assembly with a cap-style mount was purchased as an upgrade from the standard Stationary Cap Style Truck Assembly, it also slips over the top of the flagpole and is secured with the three stainless steel set screws. With the capability of rotating a full 360°, the Revolving Truck Assembly does not need specific positioning when mounted.

Unpack the Flagpole ball and thread the jam nut all the way up the threads. After applying a small amount of anti-seize, carefully thread the ball into the top of the truck. Be careful not to cross thread the components. Hand tighten only. After the ball is in place, use the proper size wrench to snug the jam nut against the top of the truck assembly. Secure the set screw at the top of the truck.

Optional Eagles are attached in the same manner. Consideration must be given to the direction that you want the Eagle to face. The most common application is to place the Eagle so that it will face in the same direction as the cleat.

Gently pull both ends of the halyard toward the bottom of the pole as far as they will reach. Size the halyard as desired. Some people want the halyard to reach the ground and some would prefer it shorter so there is not as much to wrap on the cleat. After deciding your desired length, cut off the extra length and

very carefully fuse the end of the halyard with a hot blade or flame. Thread one flag snap over each end of the halyard and loosely tie in place with an overhand knot. Final adjustment for the flag size can be made before attaching the flag. Tie the ends of the halyard together with a square knot, and wrap it onto the cleat.

If your flagpole came with the optional collar, gently slide the collar up the pole from the bottom and tape it out of the way near the cleat. Using some of the paper in which the shaft was wrapped will provide further protection to the finish.

5. Setting the Flagpole into the Ground Sleeve When placing a flagpole in the setting tube, consideration should be given to turning the shaft so that, if the truck assembly is stationary or non-revolving, the truck will be facing the direction which is opposite from the direction that the prevailing winds in your area come from. This will increase the chances of the wind and flag flowing in the same direction. If the optional revolving truck assembly is used, shaft direction is not important.

Single Piece Flagpole Shaft If the flagpole is a single piece shaft, raise the shaft in a safe and secure manner and carefully slide it into the setting tube, rotating it so that the cleat and truck sheave face the desired direction.

Multi Piece Flagpole Shaft If the flagpole is a multiple piece shaft, extra care must be used when setting it into the sleeve. Before standing the pole, make certain that the joints are fully seated and that the shaft is straight. **Never stand a flagpole that is not properly assembled and straight.** If a lifting device is used, never pick up the assembled pole from the top. The pole should be moved to a position that places the base of the pole close to the foundation. Prior to lifting the flagpole, make sure that any shaft joint below the lift point is securely lashed together with ratchet straps to prevent the possibility of separation during lifting. If lifting by crane, bucket truck, etc., the point of attachment should be above the pivot point or center of gravity point of the shaft so that the bottom of the shaft is the last to rise from the ground. **Caution: The flagpole joint IS NOT designed to support the weight of the bottom or middle section of the flagpole when raising a multi-sectional flagpole.**

6. Finishing Up On flagpoles with spacing between the shaft and the inside of the setting tube, make sure the flagpole is plumb and slowly fill the void between the flagpole and the ground sleeve with sharp river washed play sand – do not use silica sand. After some sand has been added, tamp sand to compact it. Add and tamp more sand until the sand is within ½” from the top of the setting tube. Caulk remainder of the distance to the top of the sleeve. Never use concrete to seal the spacing between the flagpole and the ground sleeve.

If the optional flash collar is being used, lower it on the concrete base and caulk where the shaft passes through the collar.

Adjust flag snap spacing to agree with the grommet spacing on flag to be flown. Attach flag to snaps and run to the peak. Secure the halyard to the cleat by wrapping it in a figure eight.

Congratulations ! You have just installed what many consider the best flagpole available. We are honored that you have selected a Concord Estate Flagpole from which to proudly fly the flag of your choice.

We wish to thank you for the purchase of what many feel is the best value in a flagpole available in today's market. We are pleased that you have chosen our flagpole to proudly fly the flag of your choice. We hope that you have many years of product satisfaction ahead of you.

We are proud to say that our flagpole shafts and the large majority of the components are made in America. If you encounter any problems or need items for repair or maintenance in the future, please contact the company from which you purchased the flagpole. They will contact us for the necessary parts or information. They are also an excellent source for replacement flags.

We have provided a list of parts that make up the flagpole assembly. There can be some variations when considering the options that you have chosen. Please review this list against the parts received **before** you begin the installation process. In the event that you have a shortage or damage, please contact the dealer at your earliest opportunity so that we can correct the issue. If you are using an installation service, confirm that all parts have been received and are acceptable **before** they are scheduled.

		Packed By	
Shaft	Sections	_____	_____
Finial (Ball, Eagle, Other).....	Each	_____	_____
Pulley (Truck) Assembly	Each	_____	_____
Flagpole Halyard.....	Each	_____	_____
Flag Snaps.....	Each	_____	_____
Cleat with cleat screws.....	Each	_____	_____
Flash Collar.....	Each	_____	_____
Installation Instructions.....	Each	_____	_____
Ground Sleeve.....	Each	_____	_____

Note: if you opted for the PVC sleeve assembly, it is attached to the shaft or shaft shipping tube and will not be a loose part.

Optional Items

Snap Covers	Each	_____	_____
Cleat Cover	Each	_____	_____
Halyard Channel	Each	_____	_____
Flag	Each	_____	_____
Other _____	Each	_____	_____

Date _____

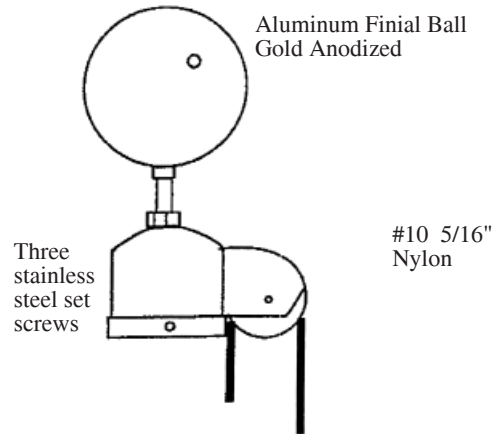
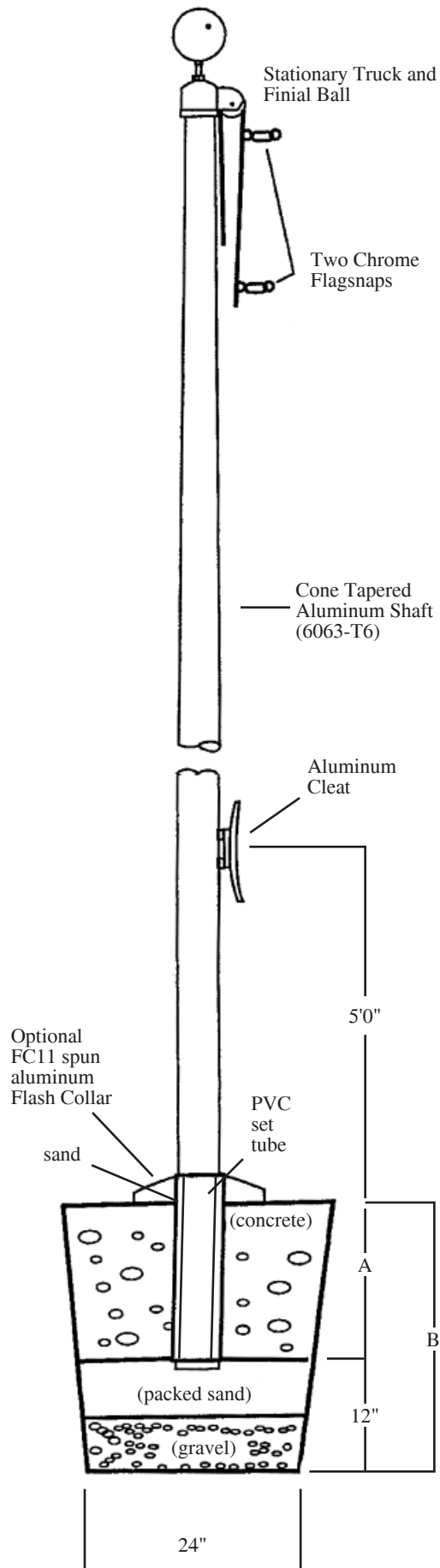

Cast Aluminum Stationary Truck with Nylon Sheave

Minimum Foundations For Firm Dry Soil

Nominal Exposed Height	"A"	"B"
15'	2'0"	3'0"
20'	2'0"	3'0"
25'	2'6"	3'6"
30'	3'0"	4'0"
35'	3'6"	4'6"

Warning: Do not allow concrete to come in contact with the aluminum shaft. Extreme caution should be exercised when installing flagpoles near overhead powerlines or in the vicinity of buried cables.