



Type	<b>ABOVE GROUND LIGHT</b>

**FEATURES & SPECIFICATIONS**

**Construction & Finish**

Seamless, die-cast aluminum housing with soft rounded corners with a hinged, die cast aluminum door frame. Continuous neoprene gasket on door frame. 0.12 nominal wall thickness of housing.

Durable polyester powder coat finish. Standard colors available: Black, Bronze, and White. Custom colors available upon request.

**Optical System**

Clear, heat, and impact resistant tempered glass lens. 16" Hydroformed optics. Type 3 IES Roadway optics. Mogul base socket with copper alloy, nickel plated screw shell and center contact.

**Lamp**

Copper wound factory tested CWA ballast with a 1000W Metal Halide lamp.

**Listing**

ETL listed.

**Warranty**

5 year warranty on the fixture and finish, one year on the ballast, and 90 days on the lamp.

**EPA RATINGS**

22" Housing	0° Tilt - EPA:	1.64
22" Housing	20° Tilt - EPA:	2.34
22" Housing	60° Tilt - EPA:	3.26

**ABOVE GROUND LIGHT SERIES**

120 / 208 / 240 / 277 Volt (Multi-Tap)  
AGCOMLGT06



**PLEASE NOTE:**

Unit comes from the factory tapped for 277 volts; but can be re-tapped in the field by a licensed electrician.

**DIMENSIONS**

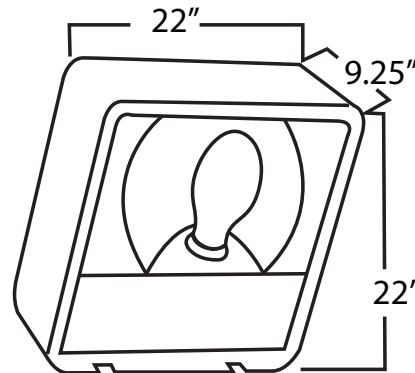

**ACCESSORIES**

**Arm Fitting Specifications**

This fixture comes with a 2AF Adjustable Knuckle Fitter, other 22" Housing requires PMVS18 for multiple units placed at 90°. For dual units placed at 180° parallel to building requires PMVS18.



2AF  
2" Adjustable  
Knuckle Fitter



PMVS18

**PHOTOMETRICS**

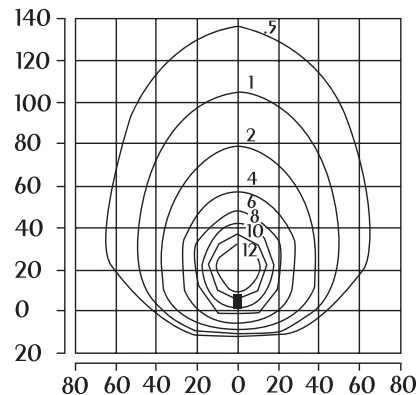

*Isofootcandle plot of 1000W MH mounted at 30' w/ 60° tilt.*