



Type	<b>ABOVE GROUND LIGHT</b>

**FEATURES & SPECIFICATIONS**

**Construction & Finish**

Seamless, die-cast aluminum housing with soft rounded corners with a hinged, die cast aluminum door frame. Continuous neoprene gasket on door frame. 0.12 nominal wall thickness of housing.

Durable polyester powder coat finish. Standard colors available: Black, Bronze, and White. Custom colors available upon request.

**Optical System**

Clear, heat, and impact resistant tempered glass lens. 16" Hydroformed optics. Type 3 IES Roadway optics. Mogul base socket with copper alloy, nickel plated screw shell and center contact.

**Lamp**

Copper wound factory tested CWA ballast with a 400W Metal Halide lamp.

**Listing**

ETL listed.

**Warranty**

5 year warranty on the fixture and finish, one year on the ballast, and 90 days on the lamp.

**EPA RATINGS**

16" Housing	0° Tilt - EPA:	.95
16" Housing	20° Tilt - EPA:	1.27
16" Housing	60° Tilt - EPA:	1.78

**ABOVE GROUND LIGHT SERIES**

120 / 208 / 240 / 277 Volt (Multi-Tap)  
AGCOMLGT05



**PLEASE NOTE:**

Unit comes from the factory tapped for 277 volts; but can be re-tapped in the field by a licensed electrician.

**DIMENSIONS**

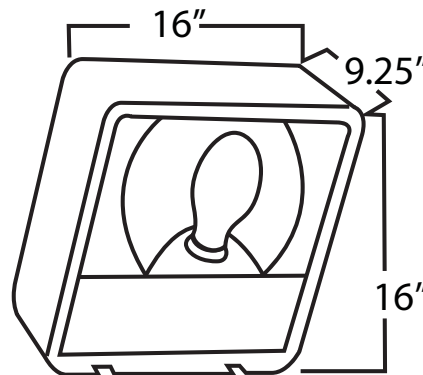

**ACCESSORIES**

**Arm Fitting Specifications**

This fixture comes with a 2AF Adjustable Knuckle Fitter, other 16" Housing requires PMV for multiple units placed at 90°. For dual units placed at 180° parallel to building requires PMVS18.



**PHOTOMETRICS**

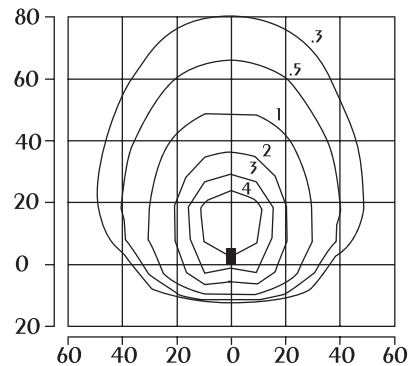

*Isofootcandle plot of 400W MH mounted at 25' w/ 60° tilt.*