



JOB NAME	
Notes	Type <b>ABOVE GROUND LIGHT</b>

## FEATURES & SPECIFICATIONS

### Application

This large rectangular HID flood light is ideal for illuminating flagpoles ranging from 40' to 50'.

### Construction & Finish

Die-cast aluminum housing with a bronze powder-coat finish.

### Lens

Clear, tempered lens furnished with a high-temperature silicone gasket for a water-tight seal. Provided with silicone gasket grease.

### Lamp

250-watt metal halide multi-tap Mogul base ED28 Clear lamp..

### Mounting

A 1/2" threaded knuckle is standard.

### Listing

ETL listed.

### Warranty

One year warranty on the fixture and finish, one year on the ballast, and 90 days on the lamp.

## ABOVE GROUND LIGHT SERIES

120 / 208 / 240 / 277 Volt (Multi-Tap)  
AGCOMLGT04

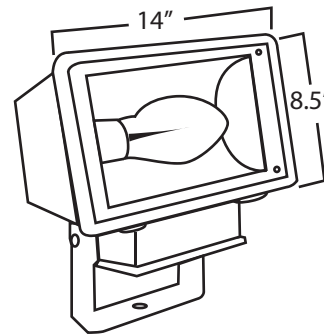

## DIMENSIONS

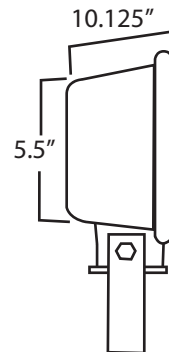

## ACCESSORIES

### Shields

- 3 Sided Shield
- 3 Sided Bug Shield
- 4 Sided Shield



### Guards

- Wire Guard
- Polycarbonate Guard



### Shields

- Tree Mount Base
- 2.5" Bullhorn Slipfitter with 1/2" hub



### Louvers

